

SBL 175-12HR

(12V 4313W)

Nominal voltage	12 V	
Nominal capacity	4247 W / 10min to 1,67 V/cell 155 Ah @ C20 to 1,75 V/cell	
Dimensions	Length	340 mm
	Width	173 mm
	Height / Total height	280 / 287 mm
Weight	~ 47,0 kg	
Technology	VRLA (Valve Regulated Lead Acid) AGM (Absorbent Glass Mat)	
Design life time	15 years (standby use)	
Internal resistance	~ 3,8 mΩ (full charged)	
Operating temperature range	Discharge	-20°C ~ +60°C
	Charge	0°C ~ +50°C
	Storage	-20°C ~ +60°C
Maximum discharge current	1550 A (5 sec.)	
Short circuit current	3150 A	
Recommended maximum charging current	46,5 A	
Charging voltage	Standby use	13,6 ~ 13,8 VDC
	Cycle use	14,6 ~ 14,8 VDC
Self discharge	Monthly is less than 3% at 25°C	
Container material	ABS UL94HB (optional UL94-V0)	
Terminal types	Internal thread M8 (breaking torque 10-12 Nm)	

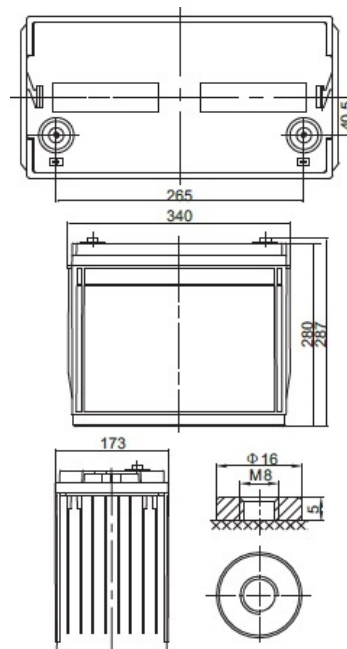

CONSTANT CURRENT DISCHARGE CHARACTERISTICS (A at 25°C)

Voltage / Time	5 min	8 min	10 min	15 min	20 min	30 min	60 min	90 min
9.6 V	541,08	463,35	416,74	331,05	265,94	194,93	112,07	83,00
10.0 V	500,67	434,65	391,02	313,80	248,07	185,83	106,80	79,02
10.2 V	479,85	419,36	376,88	304,14	238,60	180,56	103,73	76,64
10.5 V	453,22	398,39	353,90	289,88	232,07	175,47	102,02	74,93
10.8 V	426,28	377,42	330,75	275,37	225,20	170,10	100,01	73,11
11.1 V	397,81	354,88	306,65	259,69	217,34	163,81	97,61	70,92

CONSTANT POWER DISCHARGE CHARACTERISTICS (W at 25°C)

Voltage / Time	5 min	8 min	10 min	15 min	20 min	30 min	60 min	90 min
9.6 V	5789,9	5030,6	4551,9	3637,7	2932,7	2154,5	1243,6	924,6
10.0 V	5409,4	4764,8	4312,5	3481,7	2762,3	2073,9	1196,6	888,8
10.2 V	5246,4	4652,4	4205,8	3414,3	2688,3	2038,9	1176,0	872,2
10.5 V	5017,4	4476,1	3999,1	3295,4	2647,8	2006,4	1171,3	863,5
10.8 V	4787,0	4301,4	3792,4	3175,7	2606,5	1973,2	1164,7	854,8
11.1 V	4558,0	4126,8	3586,7	3056,0	2566,9	1939,0	1160,0	846,1

According with:

PN-EN 60896-21:2007	ISO 9001
PN-EN 60896-22:2007	ISO 14001
PN-EN 61056-1:2013	
PN-EN 61056-2:2013	
PN-E-83016:1999	

EFFECT OF TEMPERATURE ON LONG TERM LIFE

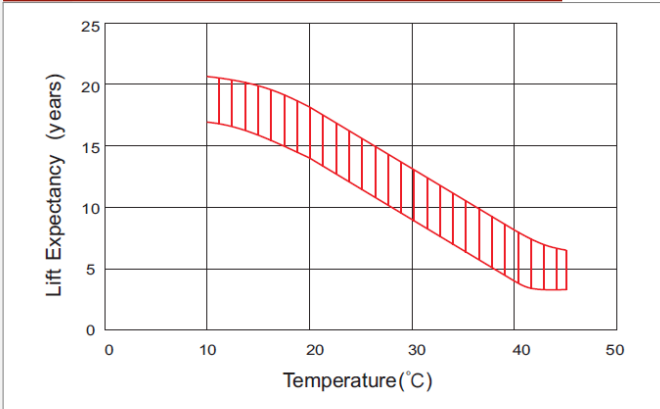

CYCLE LIFE IN RELATION TO DEPTH OF DISCHARGE

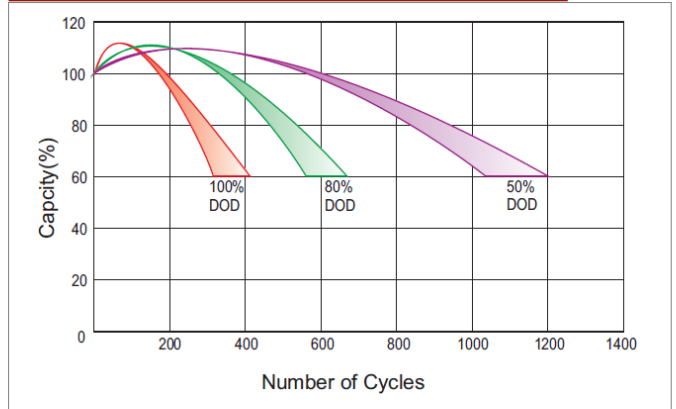

DISCHARGE CHARACTERISTICS

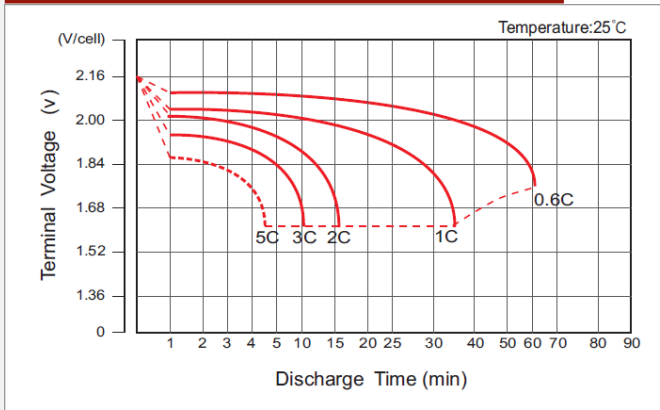

CHARGE CHARACTERISTIC FOR STANDBY USE

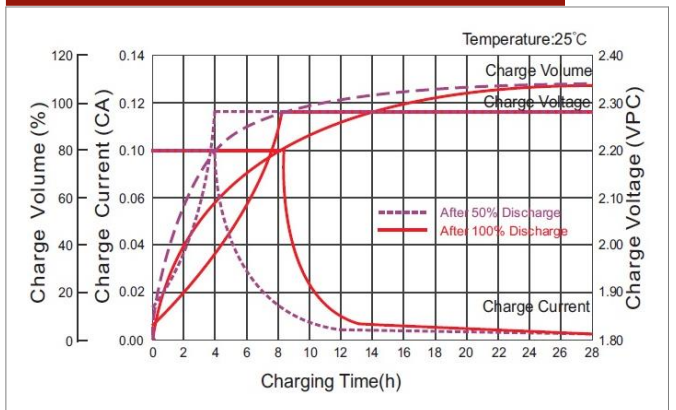

RELATIONSHIP BETWEEN CHARGING VOLTAGE AND TEMPERATURE

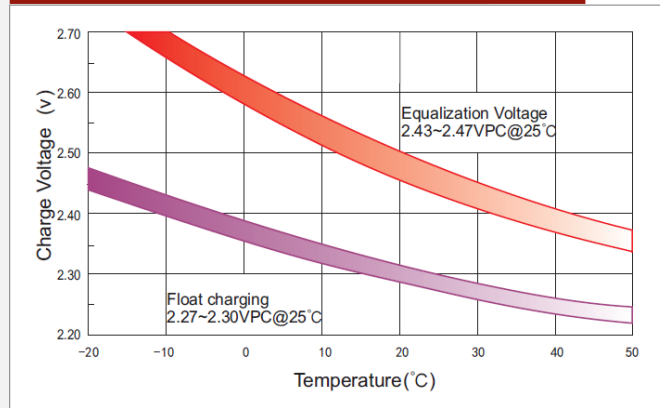

STORAGE CHARACTERISTICS

