

LC-QA1242P

FOR STANDBY POWER SUPPLIES.
EXPECTED TRICKLE DESIGN LIFE: 15 YEARS AT 20°C.

DIMENSIONS (MM)

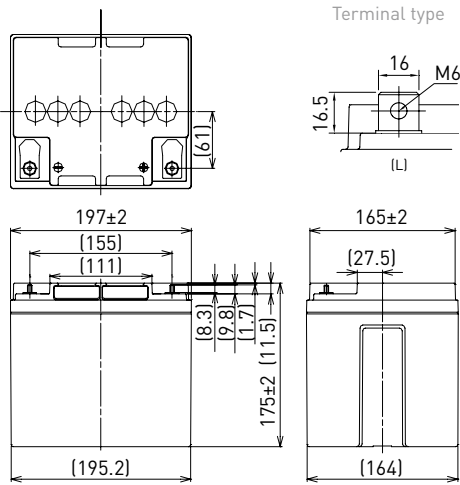

Contents indicated (including the recycle marking, etc.) are subject to change without notice. Battery case resin: flame-retardant (UL94 V-0)

Specifications		LC-QA1242P
Nominal voltage (V)		12
Nominal capacity	20 hours rate (Ah)	42.0
Dimensions	Length (mm)	165
	Width (mm)	197
	Total height (mm)	180
Approx. mass (kg)		15.5
Terminal type		M6 bolt/nut
Capacity (25°C)	20 hours rate (Ah)	47.0
	10 hours rate (Ah)	45.0
	3 hours rate (Ah)	36.0
	1 hour rate (Ah)	29.0
Impedance (mΩ)	Fully charged battery (25°C)	8
	Temperature dependency of capacity (%) - 20 hours rate	
	40°C	102
	25°C	100
	0°C	85
	-15°C	65
Remaining capacity (25°C)	After 3 months (%)	91
	After 6 months (%)	82
	After 12 months (%)	64

DURATION OF DISCHARGE VS. DISCHARGE CURRENT

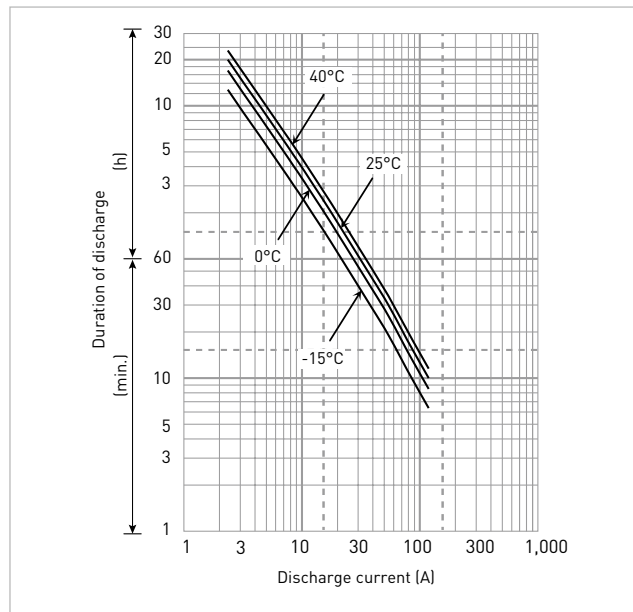

WATT TABLE (25°C)

(Wattage/battery)

Cut-off	10min.	15min.	20min.	30min.	45min.	1h	1.5h	2h	3h	4h	5h	6h	10h	20h
9.6V	1,313	993	805	621	444	354	256	220	156	121	101	86.0	55.2	28.1
9.9V	1,252	930	775	597	435	349	253	215	152	117	98.9	84.5	54.3	28.1
10.2V	1,187	868	724	574	425	344	249	205	149	116	97.6	83.2	53.9	28.1
10.5V	1,176	847	694	545	414	327	237	202	142	113	93.4	79.4	50.4	26.9
10.8V	1,170	826	673	517	405	320	231	195	139	110	90.2	76.9	49.1	25.1

AMPERE TABLE (25°C)

(Ampere/battery)

Cut-off	10min.	15min.	20min.	30min.	45min.	1h	1.5h	2h	3h	4h	5h	6h	10h	20h
9.6V	123	94.5	81.0	60.1	39.3	29.8	23.0	17.8	12.5	10.4	8.44	7.43	4.50	2.36
9.9V	121	93.4	79.9	58.4	39.0	29.6	22.3	17.7	12.3	10.3	8.35	7.37	4.50	2.36
10.2V	119	92.3	78.8	57.3	38.9	29.4	20.7	17.4	12.0	10.2	8.30	7.31	4.50	2.36
10.5V	116	90.0	77.6	56.3	38.8	29.3	20.1	16.9	11.9	10.1	8.26	7.20	4.50	2.36
10.8V	107	86.6	75.4	55.1	37.4	28.1	19.1	16.4	11.5	9.90	8.21	7.09	4.50	2.36

All mentioned values are average values

LC-QA1242P

CHARGING METHOD (25°C)

Cycle use	Control voltage: 13.6V - 13.8V Initial current: 6.30A or smaller
------------------	---

CUT-OFF VOLTAGE

Discharge current	2.10A - 8.40A	8.40A - 21.0A	21.0A - 42.0A	42.0A - 84.0A	84.0A - 126A
Cut-off voltage	10.5V	10.2V	9.9V	9.3V	8.7V

INFLUENCE OF TEMPERATURE ON TRICKLE LIFE

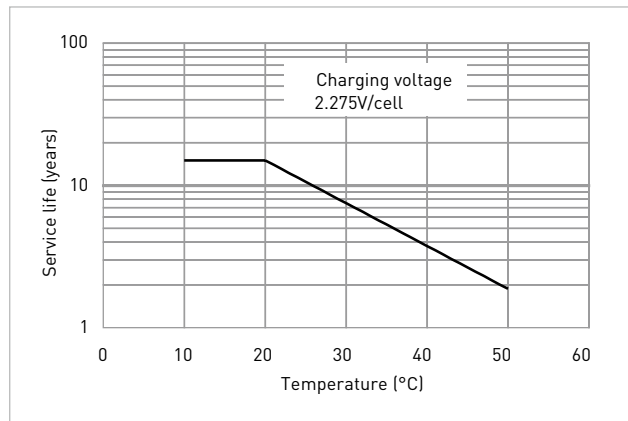

RESIDUAL CAPACITY TEST RESULT

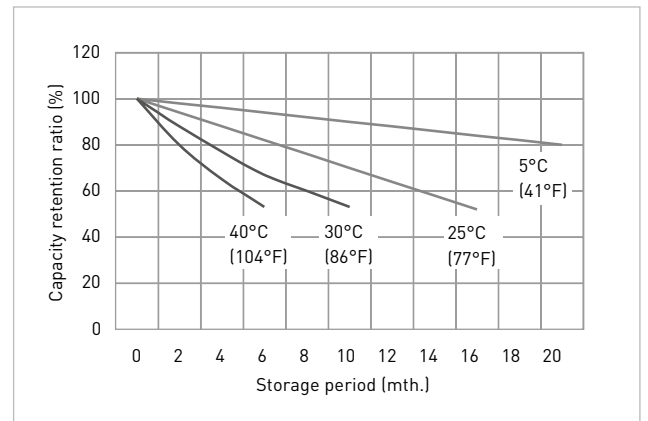

CONSTANT-VOLTAGE CONSTANT-CURRENT CHARGE CHARACTERISTICS FOR TRICKLE USE

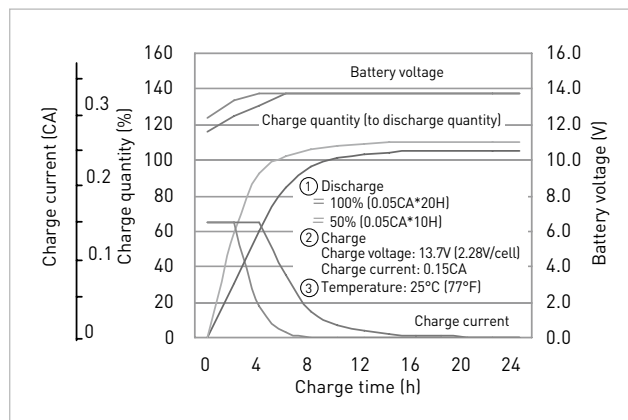

DISCHARGE CAPACITY BY TEMPERATURE AND BY DISCHARGE CURRENT

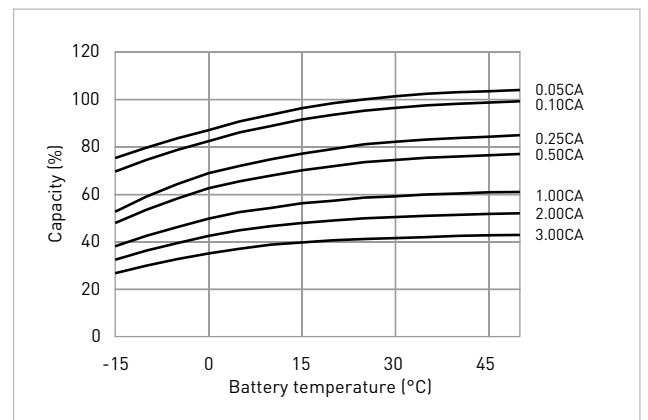

DISCHARGE CHARACTERISTICS

